

**ARKA SERVO SİPER, 45 - 90 DERECE VE
TESTERE AŞAĞI & YUKARI OTOMATİK**



3800 & 3200 FUL OTOMATİK / FULL AUTOMATIC

REAR SERVO FENCE, 45-90 DEGREE AND SAW UP & DOWN AUTOMATIC



TEKNİK ÖZELLİKLER / TECHNICAL INFORMATIONS

TABLA EBADI / TABLE SIZE
SERVO DAYAMA SİPERİ KESME BOYU/ REAR SERVO FENCE CUTTING LENGTH
ALUMİNYUM ARABA ÖLÇÜLERİ / DIMENSIONS OF SLIDING TABLE
ARABA KESME BOYU / CUTTING LENGTH
İLAVE PROFİL ARABA ÖLÇÜLER / DIMENSIONS OF ADDITIONAL TABLE
KESİCİ TESTERE MOTOR GÜCÜ / SAW BLADE MOTOR POWER
KESİCİ TESTERE DEVRİ / SAW BLADE R.P.M
KESİCİ TESTERE ÇAPI / SAW BLADE DIAMETER
KESİCİ TESTERE DELİK ÇAPI / SAW BLADE HOLE DIAMETER
KESİM YÜKSEKLİĞİ 90° / CUTTING HEIGHT 90°
KESİM YÜKSEKLİĞİ 45° / CUTTING HEIGHT 45°
ÇİZİCİ TESTERE MOTOR GÜCÜ / SCORING BLADE MOTOR POWER
ÇİZİCİ TESTERE DEVRİ / SCORING BLADE R.P.M
ÇİZİCİ TESTERE ÇAPI / SCORING BLADE DIAMETER
MONTAJLI ÖLÇÜLERİ (BOY X EN X YÜKSEKLİK) / MOUNTED DIMENSIONS
SEVKİYAT ÖLÇÜLERİ (BOY X EN X YÜKSEKLİK) / TRANSPORTATION DIMENSIONS (LXWXH)
TAKRİBİ AĞIRLIK / WEIGHT

3800 FUL OTOMATİK / FULL AUTOMATIC

1.055 X 635 MM
1.400 MM
360 X 3800 MM
3800 MM
1300 X 65 MM
4 KW - 5.5 HP 3000 DEV/DAK (R.P.M)
3.000 X 4000 X 5.000 DEV/DAK (R.P.M)
MAKSİMUM Ø 400 MM. MİNİMUM Ø 200 MM.
Ø 30 MM.
Ø 400 MM 130 MM. / Ø 300 MM 80 MM.
Ø 400 MM 105 MM. / Ø 300 MM 65 MM.
0,75 KW - 1 HP 3,000 D/D
7,000 D/D (R.P.M)
DIŞ Ø 125 MM (OUTER)/ DELİK Ø 20 MM (INNER)
4 M X 4 M X 1.5 M
2.2 M X 4 M X 1.1 M
920 ±20 KG

3200 FUL OTOMATİK / FULL AUTOMATIC

1.055 X 635 MM
1.400 MM
360 X 3200 MM
3200 MM
1300 X 65 MM
4 KW - 5.5 HP 3000 DEV/DAK (R.P.M)
3.000 X 4000 X 5.000 DEV/DAK (R.P.M)
MAKSİMUM Ø 400 MM. MİNİMUM Ø 200 MM.
Ø 30 MM.
Ø 400 MM 130 MM. / Ø 300 MM 80 MM.
Ø 400 MM 105 MM. / Ø 300 MM 65 MM.
0,75 KW - 1 HP 3,000 D/D
7,000 D/D (R.P.M)
DIŞ Ø 125 MM (OUTER)/ DELİK Ø 20 MM (INNER)
4 M X 3.4 M X 1.5 M
2.2 M X 3.4 M X 1.1 M
870 ±20 KG

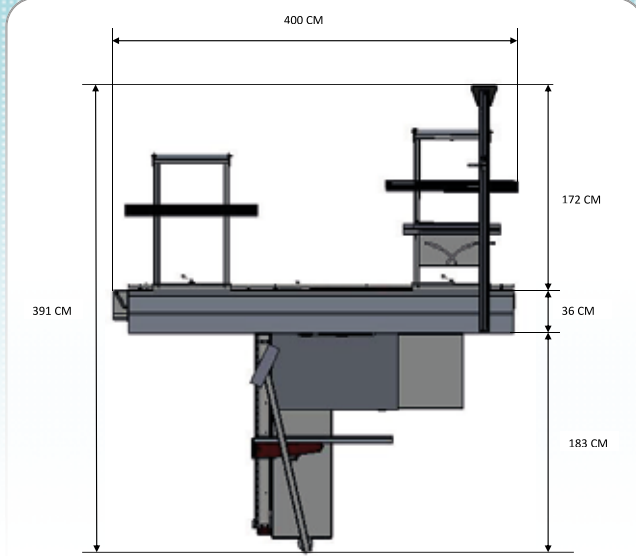

FUL OTOMATİK ÇİZİCİLİ YATAR DAİRE MAKİNASI 3800 YERLEŞİM PLANI
FULL AUTOMATIC CIRCULAR SAW 3800 LAYOUT PLAN

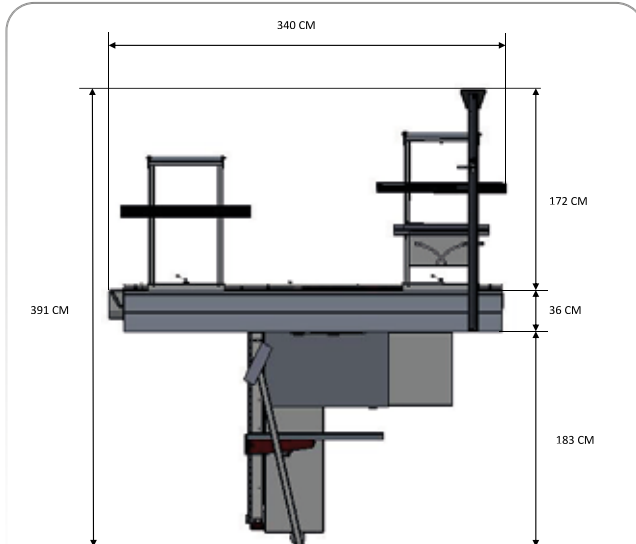

FUL OTOMATİK ÇİZİCİLİ YATAR DAİRE MAKİNASI 3200 YERLEŞİM PLANI
FULL AUTOMATIC CIRCULAR SAW 3200 LAYOUT PLAN



▶ DOKUNMATİK EKRANI VARDIR. TÜRKÇE VE İNGİLİZCE DİL SEÇENEĞİ VARDIR. IT HAS TOUCHABLE SCREEN. TURKISH AND ENGLISH USER LANGUAGES.



▶ TESTERE AŞAĞI YUKARI VE 45-90 DERECE AÇI HAREKETİ OTOMATİKTİR. SCORER SAW REGULATION EASY.



▶ HASSAS SERVO MOTORLU ALUMİNYUM SİPER DOKUNMATİK EKRANDAN AYARLANABİLMEKTEDİR. REAR SERVO ALUMINIUM FENCE CAN BE REGULATED FROM TOUCHABLE SCREEN.



▶ ÖN GÖVDE LED IŞIKLIDIR. AÇILAR DİJİTAL EKRANDAN HASSAS BİR ŞEKİLDE GÖRÜLEBİLMEKTEDİR. FRONT BODY HAS LED LIGHT. SAW DEGREE CAN BE SEEN SENSITELY.

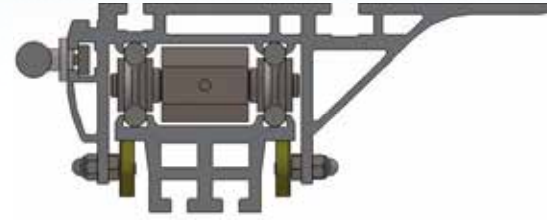

▶ 4 ADET İNDÜKSİYON MİLLİ VE MAKARALI, AĞIR ALUMİNYUM ARABASI VARDIR. ALUMINIUM SLIDING TABLE IS STRONG AND HAVE 4 CHROME INDUCTION MILES.



▶ KULLANIŞLI TOZEMME SİSTEMİ VARDIR. TOZEMME MAKİNALARINIZI BAĞLAMAZ İÇİN MAKİNADA PRİZ BULUNMAKTADIR. USEFULL DUST COLLECTOR SYSTEM. THERE IS A SOCKET ON THE MACHINE FOR CONNECTION WITH MACHINE AND DUST COLLECTOR.



▶ 3.7 METRE AÇILAN MERCEKLİ ALUMİNYUM SİPERİ VARDIR. LONG ALUMINIUM PROFILE CAN BE OPENED 3.7 METER.



▶ KOLLARIN MİLLERİ KROMLUDUR. MAKARALARI ÇİFT RULMANLI VE ÇELİKTİR. UZUN YILLAR VERİMLİ VE SORUNSUZ ÇALIŞIR. CHROME MILES. ROLLER IS STEEL AND HAS 2 BEARINGS. IT WORKS LONG YEARS EFFICIENTLY

EL KORUMA SİSTEMİ SAFETY SYSTEM

EL KORUMA İSTEMİYLE İSTENMEYEN KAZALARA ENGEL OLABİLİRSİNİZ. OKULLARDA VE İMALATHANELERDE ÖĞRENCİLER VE ÇALIŞANLARIN GÜVENLİĞİNİ KORUMAK SİZİN ELİNİZDEDİR. EL KORUMA SİSTEMİNİN TEPKİ SÜRESİ 5 MİLİSANİYEDİR VE BU SÜRE KAZALARDA HAVA YASTIĞININ AÇILMA SÜRESİNDEN 10 KAT DAHA HIZLIDIR.

SAFETY SYSTEM CAN AVOID UNDESIRABLE ACCIDENTS. SAFETY SYSTEM REACTION TIME 5 MILLISECONDS. STOPPING TIME IS 10 TIME FASTER THAN OPENING AIRBAGS IN CAR.



PNÖMATİK BASKI PNEUMATIC PRESS

3 BARLIK BASINÇ İLE ÜSTTEN BASKI YAPAR. BÜYÜK LEVHALARINIZI SIKIŞTIRARAK TEK KİŞİ RAHAT BİR ŞEKİLDE KESİM YAPABİLİRSİNİZ. DAR VE AÇILI PARÇALARINIZIDA RAHAT BİR ŞEKİLDE KESEBİLİRSİNİZ.

PNEUMATIC PRESS WILL BE FIX MATERIAL WITH 3 BAR PRESSURE. ONE PERSON CAN FIX AND CUT BIG MATERIALS EASILY.



7,5 HP - 10 HP KESİCİ MOTOR 7,5 HP - 10 HP MAIN SAW MOTOR

KALIN KORYAN, AHŞAP, BETOPAN, KOMPOZİT, KESTAMİD VE POLYAMİD VB MALZEMELER İÇİN 7,5 HP - 10 HP GÜÇLÜ MOTOR SEÇENEĞİ VARDIR. THERE ARE 7,5 HP - 10 HP MOTOR OPTIONS FOR HEAVY CORIAN, WOOD, BETOPAN, COMPOSITE, POLYAMİD MATERIALS.